

# CUTTER BLADE

## REFERENCE GUIDE V. 1.0

Roland DG Portfolio 2020  
EPMT29/04/2020

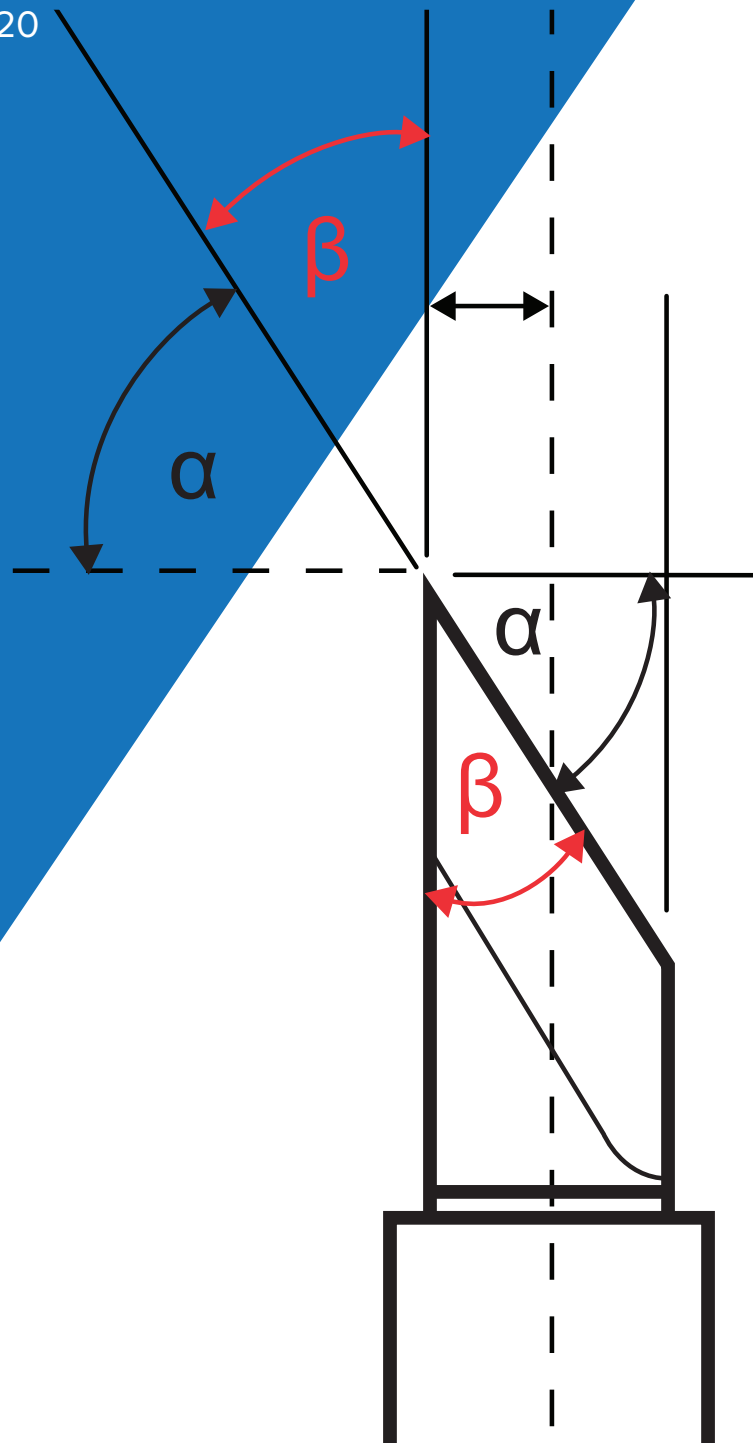

# CONTENT

- 3** Summary
  - 3** Cutter Blade Design
  - 4** Blade Extension - CutContour
  - 4** Blade Extension - PerfCutContour
  - 5** Blade Settings
  - 5** Roland DG blade portfolio
  - 6** Blade holders
  - 7** Troubleshooting
  - 9** Frequently asked questions
  - 11** Blade by application
  - 12** Blade by device
- 

# SUMMARY

This document teaches the basics of cutter blade knowledge and offers suggestions for troubleshooting cutting issues.

## CUTTER BLADE DESIGN

Below is a summary of the cutter blade terms and designs.

### ▼ OFFSET

Describes the distance from the centre of the blade to the edge of the blade and is a characteristic of the blade itself. The offset determines the blade's turning radius and how it compensates for distance while turning corners. It is specified by the blade manufacturer. The offset value can be found on the packaging of the Roland blades. One criteria to get the best cutting quality is to set up the correct offset in the cutter respectively in the connected software.

### ▼ ANGLE

The angle is specified in the measurement of degrees. There are mainly two different types of angle available:

- ▶ **Angle of cutting ( $\alpha$ )** - Angle between the surface of the foil and the leading edge of the blade. Defines the angle of cutting in direction of motion.
- ▶ **Wedge angle ( $\beta$ )** - Angle between the leading edge of the blade and the outer edge. Defines the shape of the blade.
- ▶ The blades from Roland DG will usually mention the wedge angle ( $\beta$ ), while the most standard blades mention the angle of cutting ( $\alpha$ ). It is easy to calculate the corresponding angle by subtracting the value from  $90^\circ$ . ( $\alpha + \beta = 90^\circ$ ) For example: A standard  $60^\circ$ -blade is classified as a  $30^\circ$ -blade within the Roland DG portfolio.

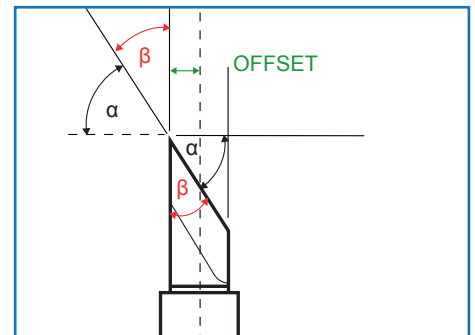

### ▼ E-RING

- ▶ Prevents the blade coming of the blade holder if used for perforated cutting on thick materials like for example cardboards.
- ▶ To change the blade, the blade holder needs to be opened. Then insert the blade from the bottom.
- ▶ Roland blades with E-Ring: ZEC-U3075 and ZEC-U3100

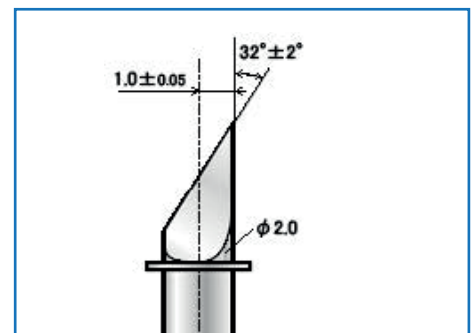

### ▼ GRINDING

Enhances the cut quality and durability of a blade.

## BLADE EXTENSION - CUTCONTOUR

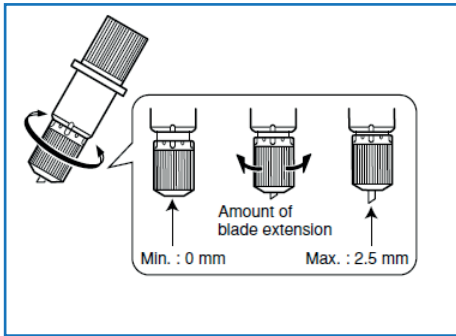

Below offers a brief overview of optimal blade extension.

- ▼ Blade extension is adjusted by twisting the blade holder's cap.
- ▼ Blade extension should be minimized for substrates. The blade is often extended too far.
- ▼ A good strategy to start with is to extend the blade the length of half the thickness of a credit card. Then send a cut test to determine if more down force is required and/or if more blade extension is required.

## BLADE EXTENSION - PERFCUTCONTOUR

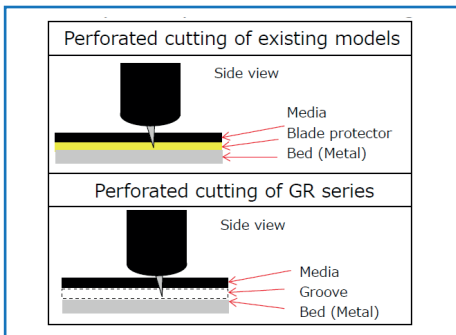

Below offers a brief overview of optimal blade extension for perforated cutting.

- ▼ No Groove in Platen (applies to Roland printer/cutters, CAMM-1 Pro GS-24 and GX-24 models)
  - ▼ The blade is extended the same length as CutContour cutting for Roland devices that do not have a designated groove for perforated cutting. The reason is the blade makes contact with the blade protection strip and overextending the blade can severely damage the cutter protection strip.
- ▼ Groove in Platen (applies to the CAMM-1 GR cutter series)
  - ▶ The blade is extended further for devices with a dedicated groove in the platen for perforated cutting.
  - ▶ A good strategy to determine how far to extend the blade is to take the material you are going to perfcut and fold it over on itself. Then drag the blade holder over the material. The ideal blade extension length is achieved when the first layer of material is cleanly cut (including through the liner) and the second layer is barely scored. If both layers are cut then the blade is extended too far. If the first layer is not cleanly cut then the blade extension length is too little.

# BLADE SETTINGS

Below lists the optimal blade settings by application. These are general guidelines only and it is always recommended to send a cut test before sending any jobs.

Material	Cutting Force	Cutting Speed
Cardboard	250 - 400 gf	≤ 20cm/s
Flock	80 - 160 gf	≤ 20 cm/s
Floor Laminate	100 - 350 gf	≤ 30 cm/s
Heat Transfer	30 - 100 gf	≤ 30 cm/s
Magnetic*	150 - 600 gf	≤ 10 cm/s
PerfCut	100 - 300 gf	≤ 30 cm/s
Reflective	100 - 350 gf	≤ 20 cm/s
Sandblast	100 - 500 gf	≤ 20cm/s
Twill	80 - 250 gf	≤ 30 cm/s
Vinyl ≤ 76 μm	30 - 100 gf	≤ 30 cm/s
Vinyl ≥ 76 μm	100 - 300 gf	≤ 30 cm/s
Window Tint	80 - 120 gf	≤ 25 cm/s



\*Magnetic foils are not officially supported on Camm-1 series

# ROLAND DG BLADE PORTFOLIO

Below lists the blades available from Roland and which applications the blade is best suited for. Please note, the list of applications is a general guideline only.

Long-lasting Premium Blades	
ZEC-U5025	For Sign-vinyl, fluorescent and reflective film, offset value 0.25mm, 5 pieces
ZEC-U5032	For Sign-vinyl, fluorescent and reflective film, offset value 0.25mm, 2 pieces
ZEC-U5022	For Sign-vinyl, fluorescent and reflective film, offset value 0.25mm, 2 pieces
ZEC-U1005	For Sign-Vinyl, offset value 0.25mm, 5pcs
ZEC-U1715	For sandblast material only, offset value 0.25mm, 5 pieces
ZEC-U3050	For thicker material like sandblast, cardboard or thick vinyl, offset value 0.50mm, 5 pieces
ZEC-U3017	For Sign-vinyl and especially small letters and details, offset value 0.175mm, 3 pieces
ZEC-U3075	For thicker material like sandblast, cardboard or thick vinyl, equipped with E-Ring, offset value 0.75mm, 5 pieces
ZEC-U3100	For thicker material like sandblast, cardboard or thick vinyl, equipped with E-Ring, offset value 1.0mm, 5 pieces
ZEC-U5010	For very thin media especially window tint, offset value 0.50mm, 2 pieces

Standard Blades	
ZEC-A5025-3	For thick vinyl and reflective film, offset value 0.25mm, 3 pieces
ZECA-1005-3	For Sign-Vinyl, offset value 0.25mm, 3 pcs
ZECA-1715-3	For sandblast material, offset value 0.25mm, 3 pieces
ZECA-3050-5	For thicker material like sandblast, cardboard or thick vinyl, offset value 0.50mm, 5 pieces
ZECA-3017-3	For Sign-vinyl and especially small letters and details, offset value 0.175mm, 3 pieces

## BLADE HOLDERS

Below lists the blade holders available from Roland. XD-CH4 is suitable for most of the older cutters and print / cut devices.

	XD-CH2	XD-CH3	XD-CH4
<b>Material</b>	Aluminium	Plastic	Aluminium
<b>Design</b>	Flat cap edge	Flat cap edge	Carved shape cap edge
<b>Mechanism</b>	Single ball-bearing	Single ball-bearing	Dual ball-bearing
<b>Standard accessory</b>	XR, LEC	Stika, BN-20, VS-Series, TrueVis	Camm-1 GR-series
<b>Type</b>	One type only	One type only	Blue, orange and red (no difference in function)



# TROUBLESHOOTING

Below summarizes common cutting issues and possible solutions.

## INCOMPLETE CUTS

- ▼ Problem: **Vinyl is not cut all the way through**
- ▼ Possible **Solutions**:
  - ▶ The blade is dull or chipped.
  - ▶ Improper blade extension.
  - ▶ The pressure is not high enough.

## STITCH CUT OR DASH CUT

- ▼ Problem: **Cut lines appear as dashes**
- ▼ Possible **Solutions**:
  - ▶ The cutter protection strip is damaged and needs to be replaced.
  - ▶ The blade is dull or chipped.
  - ▶ The speed is set too low.
  - ▶ The blade holder needs to be replaced.

## CIRCLES DON'T CLOSE

- ▼ Problem: **Vectors do not connect according to artwork on screen**
- ▼ Possible **Solutions**:
  - ▶ Replace font with Sans Serif fonts. Serif fonts have sharp angled corners and the blade can't turn fast enough to close the corners.
  - ▶ Points need to be rounded. (E.g. vector graphics that have small angles like serif fonts. e.g. -flame tips)
  - ▶ Incorrect blade offset.

## SMALL LETTERS AND SHAPES LIFT UP DURING CUTTING

- ▼ Problem: **Adhesive gets stuck together while cutting**
- ▼ Possible **Solutions**:
  - ▶ Use vinyl with a different adhesive because some adhesives don't adhere to the liner well enough for small detail. Removable/low tack adhesives are most common problem.
  - ▶ Increase blade extension because adhesive may be too thick and is not being cut all the way through.
  - ▶ Replace blade with a sharper blade to ensure it can cut through the adhesive.
  - ▶ Use a blade with a higher angle. Low angle blades may not cut through adhesive effectively.
  - ▶ Increase pen pressure because the liner could be soft and is absorbing the adhesive causing it to gel together.

## CURVED CORNERS

- ▼ Problem: **Corners don't look right.**
- ▼ Possible **Solutions**:
  - ▶ The offset is not correct. See topic "offset" and "frequently asked questions".





## FREQUENTLY ASKED QUESTIONS

- ▼ What is the recommended basic equipment?  
In cases of having different materials and applications to cut the following blades could be a basic:
  - ▶ ZEC-U5032 (default blade for GR and TrueVis): Cemented carbide blade for fluorescent and reflective film and vinyl film, offset value 0.25mm, 2 pieces (Standard angle 35°)
  - ▶ ZEC-U3050: Recommended for thick foils (Flex, Flock, Sandblast) or small letters, offset value 0.50mm, 5 pieces (Standard angle 58°)
  - ▶ ZEC-U5010: For very thin material like window tints, offset value 0.50mm, 2 pieces (Standard angle 35°, but dedicated for very thin material)
  
- ▼ Why not use the ZEC-U3050 / or 60° type blade for everything?  
If the blade can be used for thick materials as well as for small letters why should I not just keep the 60° type in the machine for everything?
  - ▶ The more a blade has a “slim” shape, the smaller the objects to be cut can be in general. Thick materials to cut requires more force. A 60° blade has less blade contact with the media, which reduces the required cutting force. But the contact with the media is much smaller than with a 45° blade. Means only small cutting face and therefore shorter lifetime.
  - ▶ The blade edge of a 45° type is running more parallel to the media and the cutting wear is spread over a larger section of the blade. The lifetime is therefore longer used with normal vinyl's.
  
- ▼ When to replace a blade?
  - ▶ In case you begin to see a decreasing cut quality or if you have problems weeding your vinyl, look at the blade and for chips along the cutting edge. Sometimes the damage might be not obvious. In this case, test if the quality improves with a new blade.
  
- ▼ How long does a blade last?
  - ▶ There is no standard expiration date set for blades. It highly depends on how much and what kind of material and you cut. Lifetime of the blades improves if blade type is aligned to material, pressure, speed and blade exposure.
  
- ▼ Any maintenance required?
  - ▶ From time to time, check the blade holder. Small pieces of the cut material might block a proper rotation of the blade and influence the cutting quality. Keep the blade and blade holder free.

- ▼ How much of the blade should be exposed for a normal cut?
  - ▶ If the blade is clearly visible and the tip being felt, it's probably too far out! The set up should be in a way that the tip of the blade is barely visible. Drag the blade holder manually across a sheet of vinyl. If that can be weed easily, but without deep scratches on the release liner or on the backside of the liner, it should be right.
  
- ▼ How much of the blade should be exposed for a perforated cut?
  - ▶ A good strategy to determine how far to extend the blade is to take the material you are going to perfcut and fold it over on itself. Then drag the blade holder over the material. The ideal blade extension length is achieved when the first layer of material is cleanly cut (including through the liner) and the second layer is barely scored. If both layers are cut, then the blade is extended too far. If the first layer is not cleanly cut, then the blade extension length is too little.
  
- ▼ The curved corners don't look right. What can I do?
  - ▶ In most cases the offset is wrong. See topic: "How do I find the right blade offset?"
  
- ▼ How do I find the right blade offset?
  - ▶ All Roland blades show the offset on the box. Use this offset to set up the correct value in the cutter respectively in the connected software.
  - ▶ Next to that, a wrong offset will have an influence on the cut quality:
    - Image A** demonstrates optimal offset.
    - Image B** demonstrates not enough offset (curved corners).
    - Image C** demonstrates too much offset (flaps on corners).

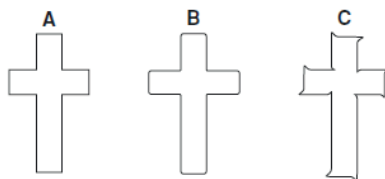

# BLADE BY APPLICATION

Below lists the blades available from Roland and which applications the blade is best suited for. Please note, the list of applications is a general guideline only.

Article Nr.	Offset	Angle (RDG, β)	Angle (Standard, α)	Packaging unit (pcs)	Cardboard	Flock	Floor Laminate	Heat Transfer	Magnetic*	PerfCut	Reflective	Sandblast	Twill	Vinyl ≤ 76 μm	Vinyl ≥ 76 μm	Window Tint
ZEC-A5025-3	0.25 mm	48°	42°	3				X						X	X	
ZEC-U5025	0.25mm	50°	40°	5				X						X	X	
ZEC-U5032	0.25mm	55°	35°	2				X						X	X	
ZEC-U5022	0.25mm	55°	35°	2												
ZECA-1005-3	0.25mm	50°	40°	3				X						X	X	
ZEC-U1005	0.25mm	50°	40°	5				X						X	X	
ZECA-1715-3	0.25 mm	33°	57°	3								X				
ZEC-U1715	0.25mm	17°	73°	5								X				
ZECA-3050-5	0.5 mm	33	57°	5	X	X	X		X		X	X	X		X	
ZEC-U3050	0.5 mm	32°	58°	5	X	X	X		X		X	X	X		X	
ZECA-3017-3	0.175mm	42°	48°	3										X	X	
ZEC-U3017	0.175mm	45°	45°	3										X	X	
ZEC-U3075	0.75 mm	32°	58°	5	X		X		X	X	X	X				
ZEC-U3100	1.00 mm	32°	58°	5	X		X		X	X	X	X				
ZEC-U5010	0.5 mm	55°	35°	2												X

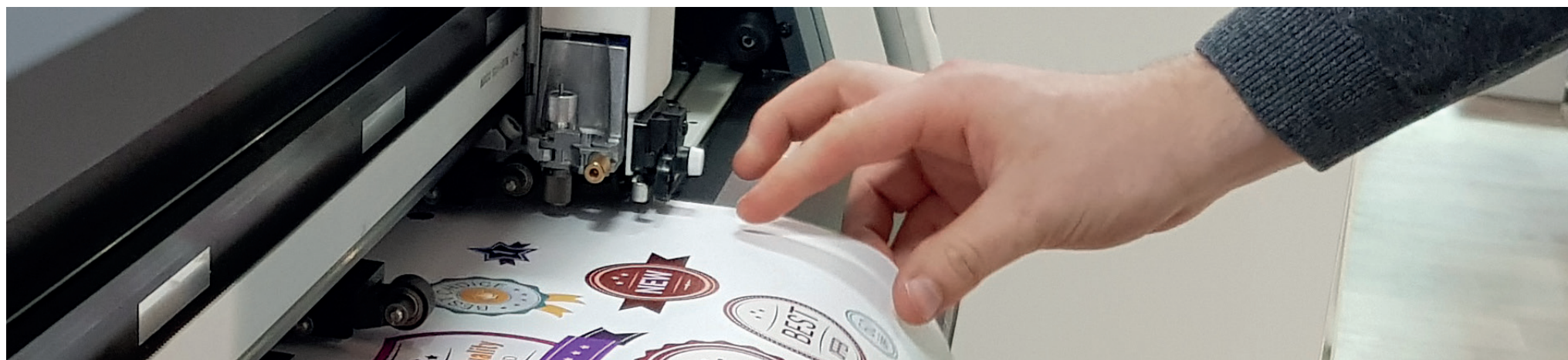

# BLADE BY DEVICE

Below lists the blades available from Roland and compatible devices with major focus on offset value and technology. Regarding applications please refer to “blades by application”, since technically a device might work with most of the blades, but they have e.g. not the right conditions like force, speed etc. to handle certain media.

Article Nr.	Offset	Angle (RDG, β)	Angle (Standard, α)	Packaging unit (pcs)	CUTTER			PRINT & CUT					
					Stika-Series	GS-24	GR-Series	BN-20	TrueVis	VSi-Series	XR-Series	LEC	LEC2
ZEC-A5025-3	0.25 mm	48°	42°	3	X	X	X	X	X	X	X	X	X
ZEC-U5025	0.25 mm	50°	40°	5	X	X	X	X	X	X	X	X	X
ZEC-U5032	0.25 mm	55°	35°	2	X	X	X	X	X	X	X	X	X
ZEC-U5022	0.25 mm	55°	35°	2	X	X	X	X	X	X	X	X	X
ZECA-1005-3	0.25 mm	50°	40°	3	X	X	X	X	X	X	X	X	X
ZEC-U1005	0.25 mm	50°	40°	5	X	X	X	X	X	X	X	X	X
ZECA-1715-3	0.25 mm	33°	57°	3	X	X	X	X	X	X	X	X	X
ZEC-U1715	0.25 mm	17°	73°	5	X	X	X	X	X	X	X	X	X
ZECA-3050-5	0.5 mm	33	57°	5		X	X		X	X	X	X	X
ZEC-U3050	0.5 mm	32°	58°	5		X	X		X	X	X	X	X
ZECA-3017-3	0.175 mm	42°	48°	3		X	X		X	X	X	X	X
ZEC-U3017	0.175 mm	45°	45°	3		X	X		X	X	X	X	X
ZEC-U3075	0.75 mm	32°	58°	5			X						
ZEC-U3100	1.00 mm	32°	58°	5			X						
ZEC-U5010	0.5 mm	55°	35°	2		X	X						
<b>Blade holder</b>													
XD-CH2				1		X					X	X	X
XD-CH3				1	X	X		X	X	X	X	X	X
XD-CH4-BL				1		X	X	X	X	X	X	X	X
XD-CH4-OR				1		X	X	X	X	X	X	X	X
XD-CH4-RD				1		X	X	X	X	X	X	X	X

X standard accessory

X compatible with this device



[www.rolanddg.eu](http://www.rolanddg.eu)

Roland DG Benelux NV | Bell-Telephonelaan 2G | B-2440 Geel